

Electronic Cruise Control for Yamaha XVS1100 V Star



The following provides a brief description of the power consumption and component locations of the MotorCycle Setup electronic cruise control.

Installed weight of the cruise control is approximately 2.5g.

Current draw while the cruise is switched on, but not engaged, is approximately 0.250 amp (3 watts). Current draw while the cruise is engaged is nominally 0.50~0.80 amp (6~10 Watts).

By comparison, a head light bulb typically draws about 4 amps (55 Watts), and a tail light bulb (running light) draws about 0.4 amp (5 Watts).

Refer to the line drawing on the back of this sheet to identify the component numbers in the text.

The **Computer (1)** and **Actuator (2)** mount inside an enclosure made for the V Star. This enclosure is made from stainless steel and is finished in satin black powder coat. It mounts in front of the engine crankcase, between the frame tubes.

A **Vacuum Hose Assembly (3)** is provided to connect the actuator to the engine.



The **Cable Interface Unit (4)** is located on the left side of the motor, beside the carburetors. The CIU is supplied with a polished stainless steel cover to enhance its appearance. We **sometimes** have stock of these covers in satin black powder coat. This might be preferable for bikes with all black painted engines. The CIU has a new **cable (5)** running from it to the carburetors.

The **Speed Sensor (6)** mounts to the left front fork using one of the brake calliper mounting bolts. Magnets are placed in the heads of the bolts that mount the brake disc.



The **Control Switch (7)** is mounted on the left hand mirror mount.

The control switch housing is normally a satin black finish (shown), however it is also available in chrome as an extra cost option.

The **Wiring Loom (8)** is a 'universal' loom, and the kit comes supplied with all the plugs and terminals that are already used on the motorcycle, and instructions for cutting and terminating the wires. Power for the cruise control and brake sensing is taken off the brake light switches by unplugging the rear brake light switch. Matching connectors on the cruise control loom are plugged in to the switch and the bike's loom. Tach (engine speed) sensing is detected from the bikes ignition coils. This is used to disengage the cruise if the clutch is operated. The bike's clutch switch is also connected to the cruise control to disengage the cruise control. The cruise control is grounded on the negative battery terminal.



For an additional fee, the wiring loom can be supplied cut and terminated to suit the bike.

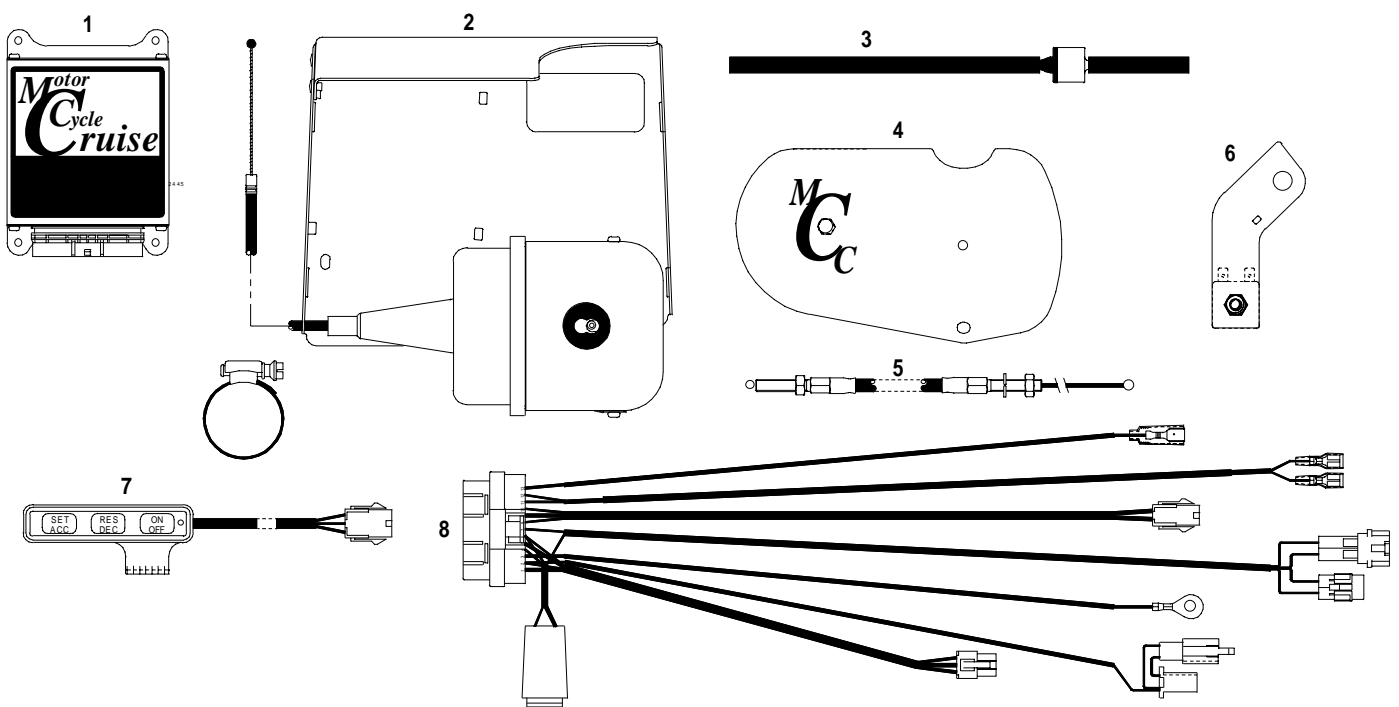

MotorCycle Setup P/L

ABN 94 798 167 654

6 Kinston Street
Mount Waverley VIC 3149
AUSTRALIA

Web Site:

<http://www.mccruise.com>

International:

Phone (International Access Code) 61 3 9808 2804

Fax (International Access Code) 61 3 9808 2445

Australia:

Phone (03) 9808 2804

Fax (03) 9808 2445

E-mail: mcsetup@bigpond.net.au