

# Electronic Cruise Control for Honda Transalp XL650V



The following provides a brief description of the power consumption and component locations of the MotorCycle Setup electronic cruise control.

Installed weight of the cruise control is approximately 2.0kg.

Current draw while the cruise is switched on, but not engaged, is approximately 0.250 amp (3 watts). Current draw while the cruise is engaged is nominally 0.50~0.80 amp (6~10 Watts).

By comparison, a head light bulb typically draws about 4 amps (55 Watts), and a tail light bulb (running light) draws about 0.4 amp (5 Watts).

Refer to the line drawing on the back of this sheet to identify the components from the numbers in the text.

The **Computer (1)** mounts in front of the tail light, under the seat. It is mounted in a **foam block (2)**.



The **Actuator (3)** is bolted to the bottom of the storage compartment under the seat and sits in the left hand front corner of the compartment. A 6.5mm (1/4") hole must be drilled in the bottom of the luggage compartment to mount the actuator, as well as holes for the vacuum hose and the actuator wiring. A **vacuum hose assembly (4)** is provided to connect the actuator to the engine.

The **Cable Interface Unit (5)** is located on the left side of the engine. A new **cable (6)** connects it to the carburetors.



The **Speed sensor (7)** is mounted on the right side of the swing arm, on one of the rear brake caliper mounting bolts. Nickel plated magnets are placed in the heads of the bolts that mount the brake disc.

The **Control Switch (8)** is mounted on the left side mirror stalk, above the bikes switch gear.



The **Wiring Loom (9)** has the same type of plugs or terminals that are already used on the motorcycle. Power for the cruise control and brake sensing is taken off the brake light switches by unplugging the rear brake light switch. Matching connectors on the cruise control loom are plugged in to the switch and the bike's loom. Tach (engine speed) sensing is detected from the bike's ignition coils. This is used to disengage the cruise if the clutch is operated. The bike's clutch switch is also connected to the cruise control to disengage the cruise control. The cruise control is grounded on the negative battery terminal.

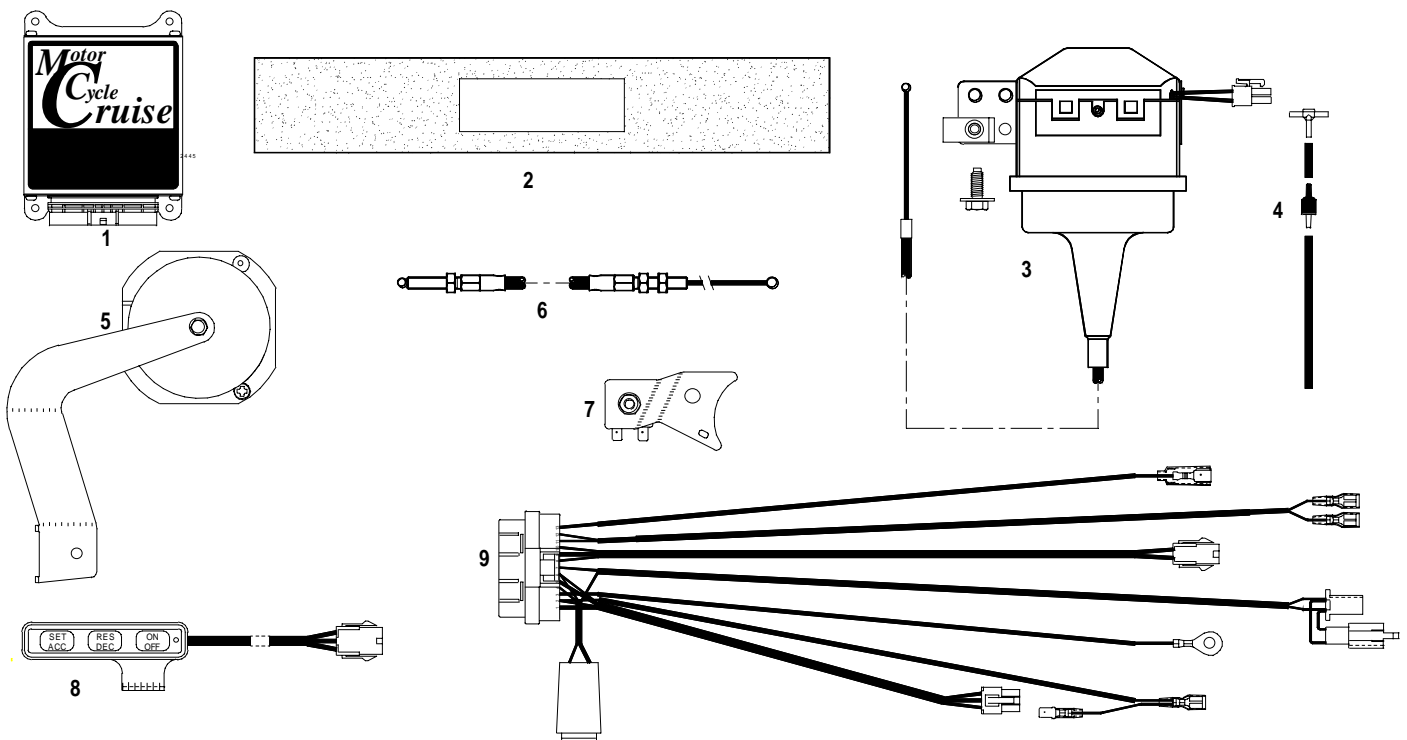

## MotorCycle Setup P/L

ABN 94 798 167 654

6 Kinston Street  
Mount Waverley VIC 3149  
AUSTRALIA

Web Site:

<http://www.mccruise.com>

International:

Phone (International Access Code) 61 3 9808 2804

Fax (International Access Code) 61 3 9808 2445

Australia:

Phone (03) 9808 2804

Fax (03) 9808 2445

E-mail: [mcsetup@bigpond.net.au](mailto:mcsetup@bigpond.net.au)