

Electronic Cruise Control for BMW R1150GS Integral ABS3

Fitted with BMW Evolution brake package



NOTE: - Before we can supply a cruise control for this model, we need to know what version of ABS brakes (or no ABS if that is the case), AND what brake calipers the bike has. See the next last pages for details.

The following provides a brief description of the power consumption and component locations of the MotorCycle Setup electronic cruise control.

Installed weight of the cruise control is approximately 2.5kg.

Current draw while the cruise is switched on, but not engaged, is approximately 0.250 amp (3 watts). Current draw while the cruise is engaged is nominally 0.50-0.80 amp (6-10 Watts).

By comparison, a head light bulb typically draws about 4 amps (55 Watts), and a tail light bulb (running light) draws about 0.4 amp (5 Watts).

Refer to the line drawing on the back of this sheet to identify the components from the numbers in the text.

The **Computer (1)** mounts below the rear of the fuel tank, behind the battery. It is mounted in a **foam block (2)**.



The **Actuator (3)** is bolted to the right side of the gearbox, using the right footrest mounting bolts. Silver Pearl (shown) or Satin Black (optional) powder coated aluminium covers are supplied to prevent dirt and water ingress into the actuator and to improve the appearance of the actuator. A **vacuum hose assembly (4)** is provided to connect the actuator to the engine.



The **Cable Interface Unit (5)** is bolted to the frame on the right side of the front suspension spring/shock absorber unit. A selection of fittings, **new cable and cable fittings and nipples (6)** are provided to allow this to be 'patched' in to the bike's throttle cable. This involves cutting the original throttle cable, fitting a new cable nipple and adjuster to it to allow connection from the bike's throttle bodies to the CIU. A new inner cable and nipple and adjuster are also fitted to the remainder of the cable from the twist grip and this is also connected to the CIU.



The **Speed sensor (7)** is mounted below the right hand front brake caliper. The original caliper mounting bolt is removed and a new bolt and spacer fitted to allows the speed sensor to be mounted. Nickel-plated magnets are placed in the heads of the bolts that mount the brake disc.



The **Control Switch (8)** is mounted on the left hand (clutch) master cylinder fluid reservoir cap. New screws are supplied to replace two of the existing reservoir cap screws. The switch is located just above the left switch block.



The **Wiring Loom (9)** is a 'universal' loom, and the kit comes supplied with all the plugs and terminals needed for connection to the motorcycle, and instructions for cutting and terminating the wires. Power for the cruise is taken from the bike's heated grip circuit. Brake sensing is detected from the connection to the brake light. Tach (engine speed) sensing is detected from the bike's tachometer signal wire. This is used to disengage the cruise if the clutch is operated. The bike's clutch switch is also connected to the cruise control to disengage the cruise control. These connections require the wires to be spliced to the bike's wiring loom because we have been unable to source the connectors used on the bike. The cruise control is grounded on the battery negative terminal.

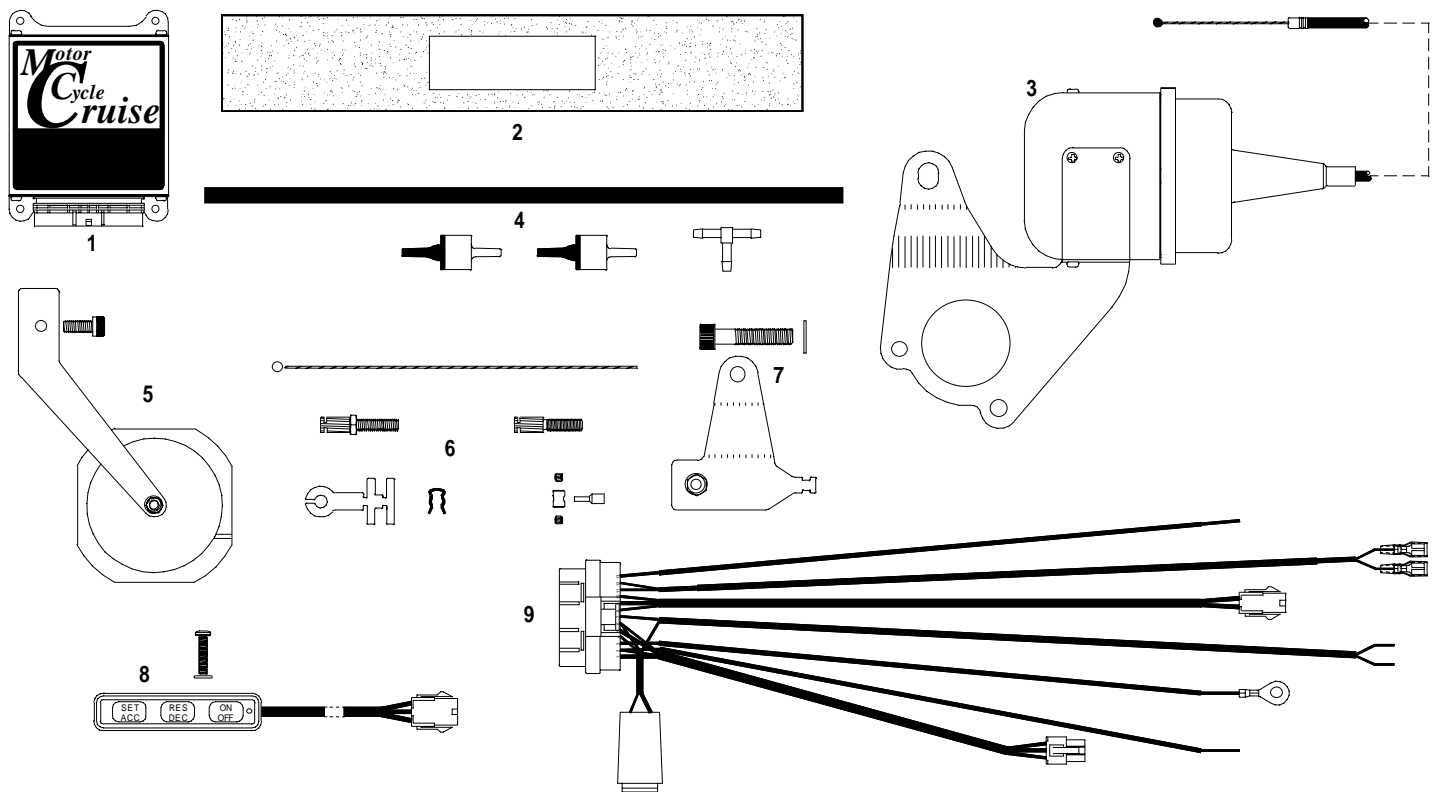

MotorCycle Setup P/L

ABN 94 798 167 654

6 Kinston Street
Mount Waverley VIC 3149
AUSTRALIA

Web Site:

<http://www.mccruise.com>

International:

Phone (International Access Code) 61 3 9808 2804

Fax (International Access Code) 61 3 9808 2445

Australia:

Phone (03) 9808 2804

Fax (03) 9808 2445

E-mail: mcsetup@bigpond.net.au

BMW R1150GS cruise control

How to determine what type of brake calipers and ABS system is fitted.

During development of the cruise control for the R1150GS we have been aware that there are two different types of front brake caliper and two different ABS systems fitted to this model, and some bikes without ABS.

In order to supply the correct kit for the bike, we need to know what type of front brake calipers your bike has, and what ABS system (if any) the bike has. This is easy to determine by following the instructions below.

Identifying the front brake calipers.

The earlier models were fitted with Brembo brake calipers.



Later models were fitted with the Evolution brake package. This included these calipers, labeled with the BMW logo.



Please specify what type of brake calipers are fitted to your bike, Brembo or BMW Evolution.

MotorCycle Setup P/L ABN 94 798 167 654

6 Kinston Street
Mount Waverley VIC 3149
AUSTRALIA

Web Site: <http://www.mccruise.com>

International: Phone (International Access Code) 61 3 9808 2804

Fax (International Access Code) 61 3 9808 2445

Australia: Phone (03) 9808 2804

Fax (03) 9808 2445

E-mail: mcsetup@bigpond.net.au

ABS (Anti-lock) brake system identification.

ABS brakes were an optional extra on the R1150GS. Some bikes will not have ABS brakes fitted. Some models were fitted with ABS 2 braking system. Later models were fitted with ABS 3 (Integral ABS). Se need to know what ABS system is fitted to the bike.

If there is no tone wheel (a metal ring with multiple slots) fitted inside the left front brake disc on the front wheel, then the bike does not have ABS brakes.

If there is a tone wheel, then the bike has ABS brakes, but you now need to determine what system. The following will allow you to identify what system it has.

Turn the ignition switch ON, but do NOT start the engine.

Wait few seconds (at least 10 seconds).

Apply either front or rear brakes and listen. If there are no noises during brake application (the noise is quite loud) then your bike has ABS 2. If there is a quite loud noise of an electric motor running, then your bike has ABS 3 (Integral ABS).

Please specify what your bike has, no ABS, ABS 2 or ABS 3.

If you correctly specify these features, we will be able to supply the correct parts in the cruise control kit for your bike.

MotorCycle Setup P/L *ABN 94 798 167 654*

**6 Kinston Street
Mount Waverley VIC 3149
AUSTRALIA**

Web Site: <http://www.mccruise.com>

International: **Phone** **(International Access Code) 61 3 9808 2804**

Fax **(International Access Code) 61 3 9808 2445**

Australia: **Phone** **(03) 9808 2804**

Fax **(03) 9808 2445**

E-mail: **mcsetup@bigpond.net.au**