

Electronic Cruise Control for Honda VTR1000F Fire Storm (Super Hawk)



The following provides a brief description of the power consumption and component locations of the MotorCycle Setup electronic cruise control.

Installed weight of the cruise control is approximately 2kg.

Current draw while the cruise is switched on, but not engaged, is approximately 0.250 amp (3 watts). Current draw while the cruise is engaged is nominally 0.50~0.80 amp (6~10 Watts).

By comparison, a head light bulb typically draws about 4 amps (55 Watts), and a tail light bulb (running light) draws about 0.4 amp (5 Watts).

Refer to the line drawing on the back of this sheet to identify the components from the numbers in the text.

The **Computer (1)** mounts in the rear of the area under the seat, on the rear of the frame with the seat lock mechanism.

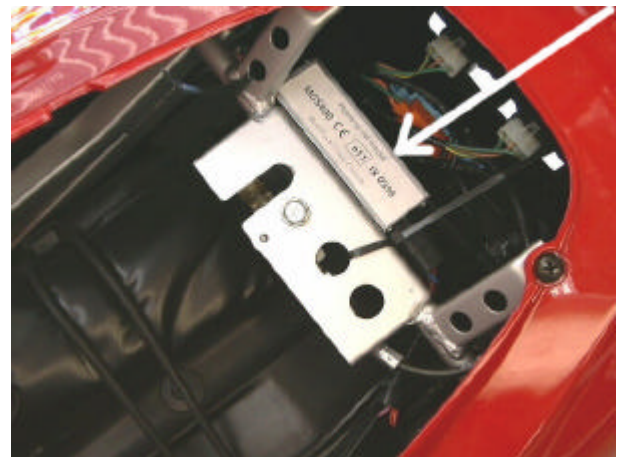

The **Actuator (2)** is bolted under the right rear pillion foot peg mounting bolts and is located beside the rear spring/damper unit, and just above the riders foot peg. Silver or black (optional) powder coated aluminium covers are supplied to prevent dirt and water ingress into the actuator and to improve the appearance of the actuator. A **vacuum hose assembly (3)** is provided to connect the actuator to the engine.

The actuator cable acts on a **lever assembly (4)** that is attached to the carburetors.



The **Switch (5)** is mounted to the left hand (clutch) master cylinder handlebar clamp. The bracket mounts between the bottom faces of the clamp and the master cylinder. The clamp must have about 1~1.5mm (0.040"~0.060") filed from the bottom face to allow for the thickness of the switch bracket.



The **Wiring Loom (6)** is a 'universal' loom, and the kit comes supplied with all the plugs and terminals that are already used on the motorcycle, and instructions for cutting and terminating the wires. Power for the cruise control and brake sensing is taken off the brake light switches by unplugging the rear brake light switch. Matching connectors on the cruise control loom are plugged in to the switch and the bike's loom. Speed sensing is taken off the bikes electronic speedometer sender. Tach (engine speed) sensing is detected from the bike's ignition coils. This is used to disengage the cruise if the clutch is operated. The bike's clutch switch is also connected to the cruise control to disengage the cruise control. The cruise control is grounded on the battery negative terminal.

For an additional fee, the wiring loom can be supplied cut and terminated to suit the bike.

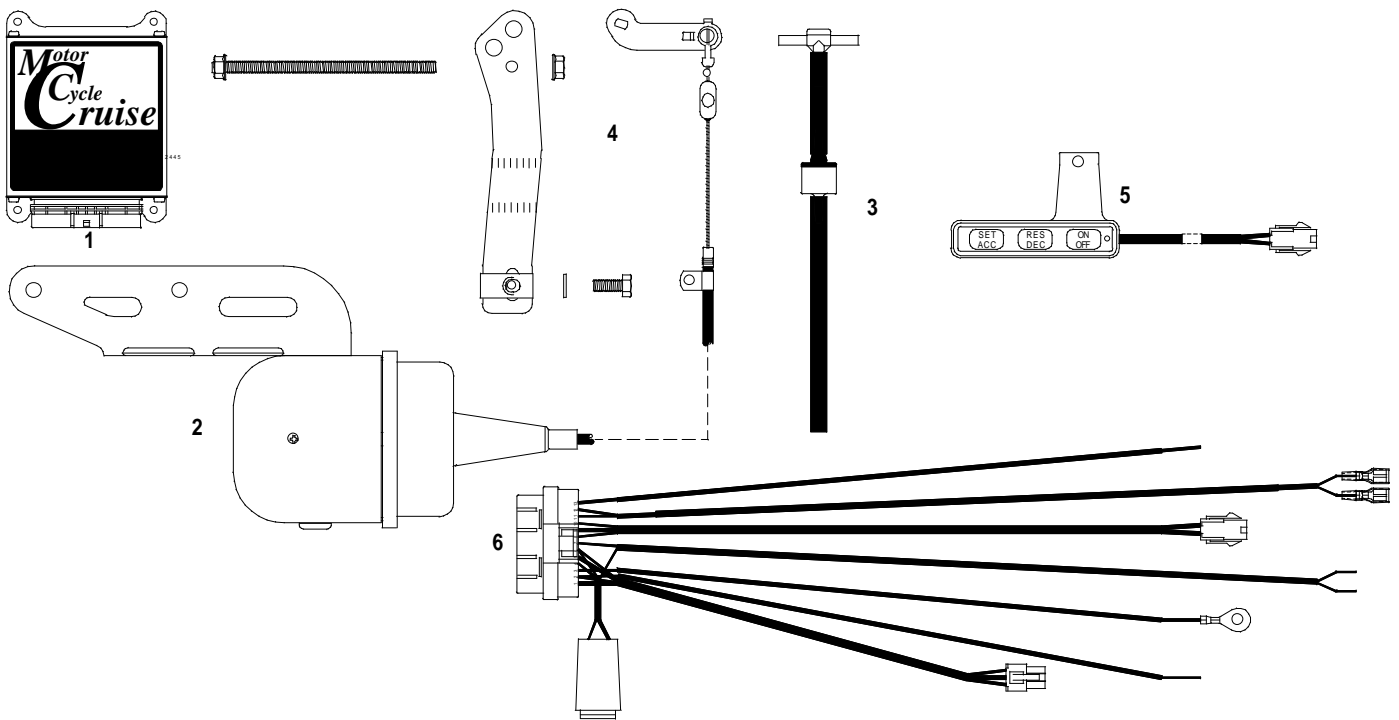

MotorCycle Setup P/L

ABN 94 798 167 654

6 Kinston Street
Mount Waverley VIC 3149
AUSTRALIA

Web Site: <http://www.mccruise.com>

International: Phone (International Access Code) 61 3 9808 2804

Fax (International Access Code) 61 3 9808 2445

Australia: Phone (03) 9808 2804

Fax (03) 9808 2445

E-mail: mcsetup@bigpond.net.au