

## *Electronic Cruise Control for*

# **BMW K1200RS ABS 1 and 2 ('97 to '01)**

NOTE: This kit will also fit later model ABS3 (Integral ABS) with some changes to the installation procedure. The **ONLY** change is how connections are made to the bike's brakes. All other parts of the installation are the same.



The following provides a brief description of the power consumption and component locations of the MotorCycle Setup electronic cruise control.

Installed weight of the cruise control is approximately 1.8kg.

Current draw while the cruise is switched on, but not engaged, is approximately 0.250 amp (3 watts). Current draw while the cruise is engaged is nominally 0.50~0.80 amp (6~10 Watts).

By comparison, a head light bulb typically draws about 4 amps (55 Watts), and a tail light bulb (running light) draws about 0.4 amp (5 Watts).

Refer to the line drawing on the back of this sheet to identify the components from the numbers in the text.

The **Computer (1)** mounts under the right side of the rear body section behind the coolant reservoir and is accessible with the seat removed.

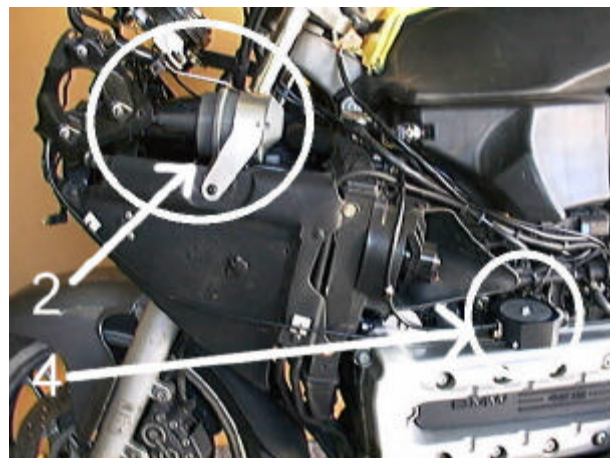

The **Actuator (2)** is mounted to the left of the front forks, just above the inner fairing panel, and below and behind the instruments. It can be seen at top left in the photo. A **vacuum hose assembly (3)** is provided to connect the actuator to the engine.

The **CIU (4)** is located on the left side of the bike above the cylinder head. It can be seen at bottom right in the photo. A new **cablE (5)** connects it to the throttles.

The **Control Switch (6)** is mounted on the left hand (clutch) master cylinder fluid reservoir cap. New screws are supplied to replace two of the existing reservoir cap screws. The switch is located just above the left switch block as shown in the photo at right.



The **Wiring Loom (7)** uses the same type of plugs that are already used on the motorcycle. Brake sensing is taken off the brake light switches by unplugging the rear brake light switch. Matching connectors on the cruise control loom are plugged in to the switch and the bike's loom. Power is also taken from the brake light circuit. Speed sensing is taken from the motorcycles speedometer sender unit from a connection at the back of the bike's instruments. Tach (engine speed) sensing is detected from the bike's ignition system using a connection at the back of the bike's instruments. This is used to disengage the cruise if the clutch is operated. The cruise control is grounded on the negative battery terminal.

The wiring loom incorporates a new safety device, the 'CruiseSafe' actuator power relay. This device is a simple relay that is operated by the brake light switches. If the cruise control should malfunction, either due to electrical interference or component failure, applying the brakes enough to turn the brake light on will instantly cut power to the cruise control actuator (servo). Releasing the brakes will restore power to the actuator. This device is fail-safe in all respects except one. The brake light switches must be operative for this device to work.

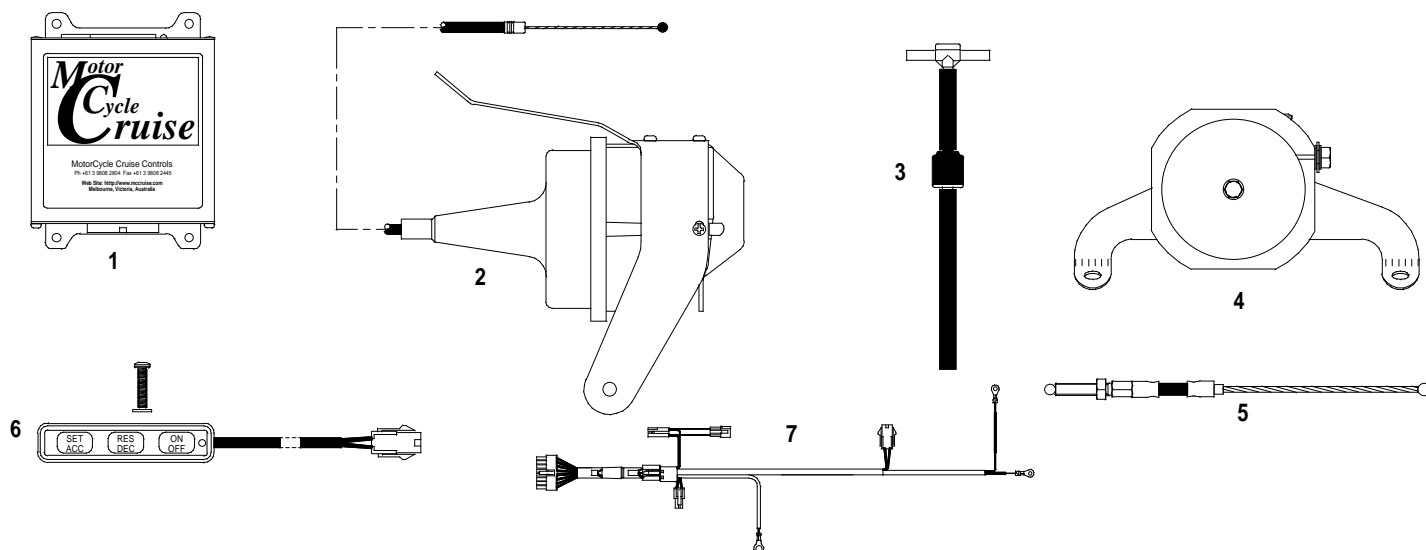

## MotorCycle Setup P/L

ABN 94 798 167 654

6 Kinston Street  
Mount Waverley VIC 3149  
AUSTRALIA

Web Site:

<http://www.mccruise.com>

International:

Phone (International Access Code) 61 3 9808 2804

Fax (International Access Code) 61 3 9808 2445

Australia:

Phone (03) 9808 2804

Fax (03) 9808 2445

E-mail: [mcsetup@bigpond.net.au](mailto:mcsetup@bigpond.net.au)